

AutoCAD File: STD11A BUREAU: CIVIL DESIGN BUREAU ENGINEER: BL 9/20/99 DRAFTSMAN: L.R.H. DATE: 9-99 SCALE: N.T.S.

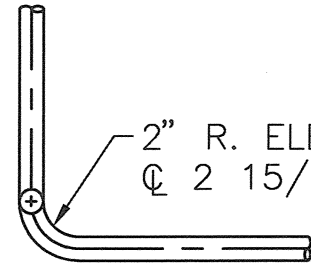

PLAN VIEW

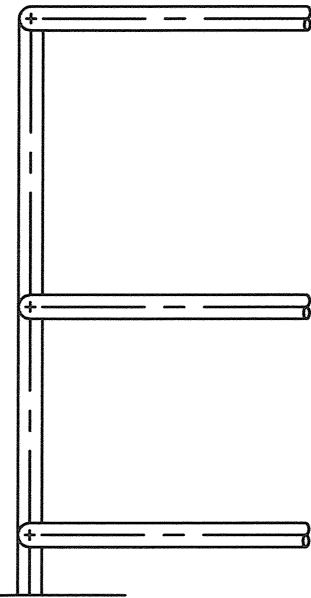

COR. PIPE RAIL

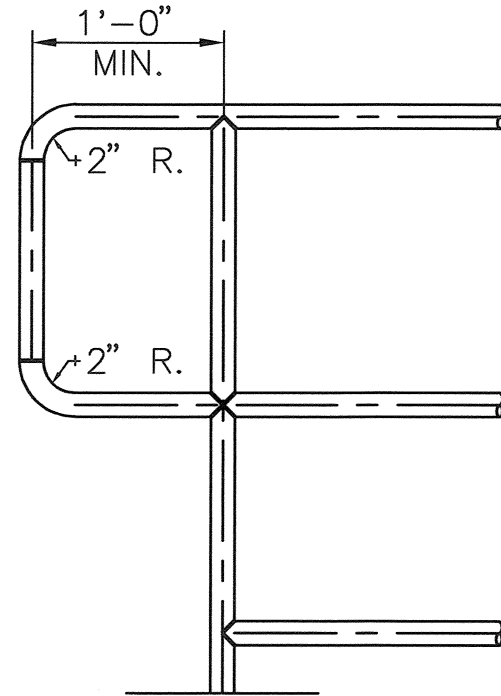

PIPE RAIL & POST CLASS
 ASTM-A-120

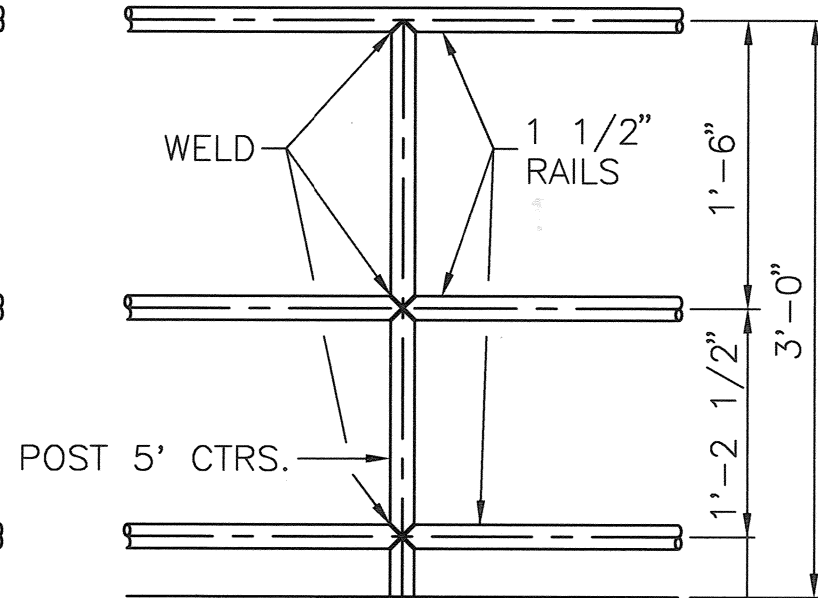

ELEVATION

** BOTTOM RAIL NOT REQUIRED IF 2" CURB IS CONSTRUCTED PER ADAAG

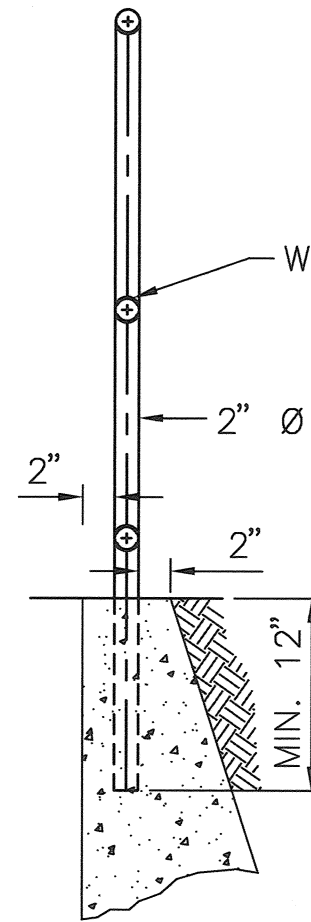

POST SET IN CONC. RETAINING WALL

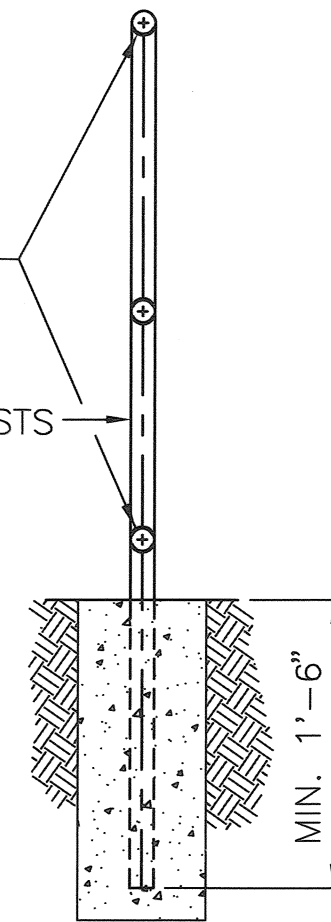

POST SET IN CONCRETE

REVISIONS			
NO.	DATE	BY	REMARKS

NOTE:
 PAINT AND PAINTING SHALL CONFORM TO THE SPECIFICATION* FOR PAINTING STEEL. AFTER SHOP FABRICATION IS COMPLETED ALL MEMBERS SHALL BE PAINTED WITH A COAT, EXCEPT THAT ONLY BOILED LINSEED OIL SHALL BE APPLIED ON THE AREAS WHERE FIELD WELDING IS TO BE DONE. TWO COATS OF PAINT SHALL BE APPLIED AFTER ERECTION HAS BEEN COMPLETED.

* AS SPECIFIED IN THE CONTRACT PLANS OR ACCORDING TO A.A.S.H.T.O.; DIVISION II, SECTION 13 OF THE 1996 EDITION WITH INTERIM REVISIONS.

CITY OF MEMPHIS
 DEPARTMENT OF ENGINEERING

DESIGN STANDARD
 FOR
ADA HAND RAIL

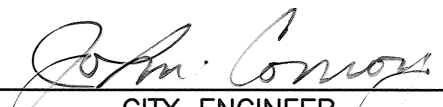
 CITY ENGINEER

9/20/99
 DATE