

NOTE: PIPE OFF CENTER. EXACT LOCATION TO BE DETERMINED IN FIELD

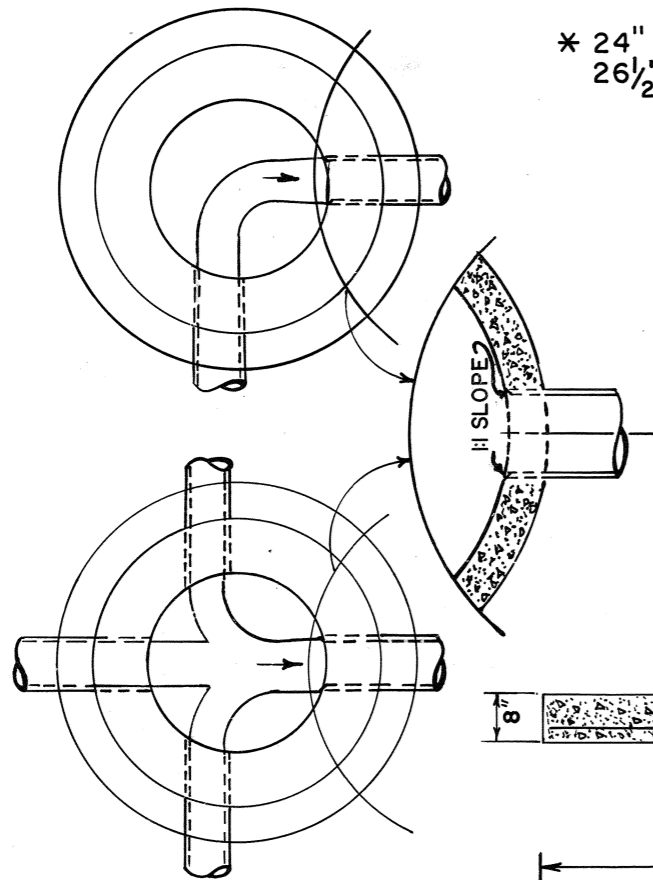

TYPICAL PLANS

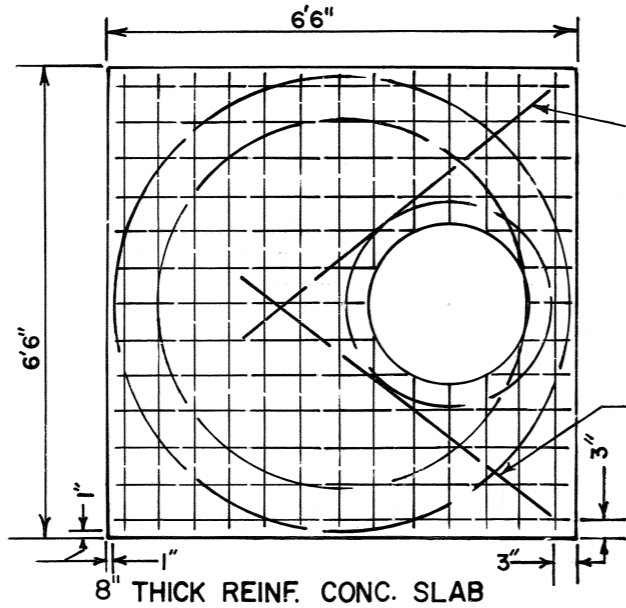
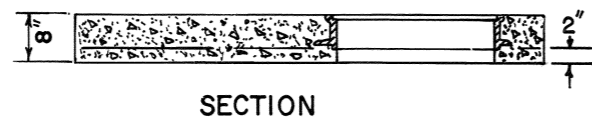

A CONCRETE SLAB 8" THICK (WITH MANHOLE FRAME LOCATED ECCENTRICALLY IN SLAB) REINFORCED WITH #4 DEFORMED STEEL BARS 2" FROM BOTTOM OF SLAB AND SPACED 6" C-C BOTH LONGITUDINALLY AND TRANSVERSELY. SLAB TO BE BUILT TO BASE OR PAVEMENT GRADE

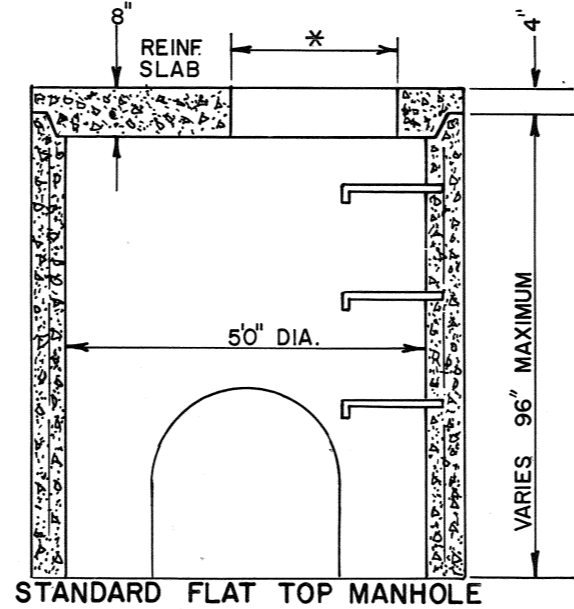

NOTE:
JOINT SEALANT CONCRETE MORTAR SHALL BE USED TO SEAL JOINTS AFTER THE INSTALLATION OF AN APPROVED GASKET BETWEEN ALL PRECAST MANHOLE SECTIONS.

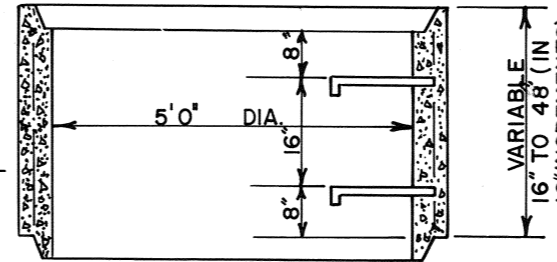
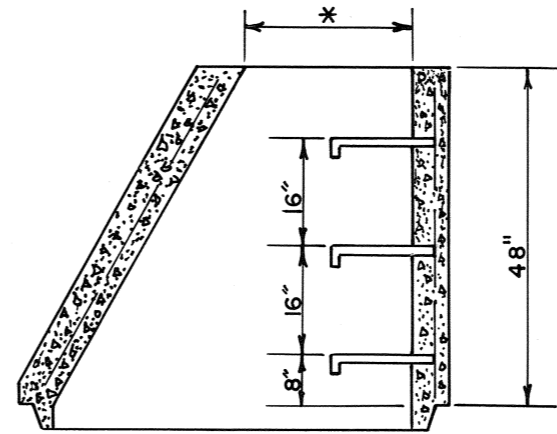

WALL THICKNESS EQUALS PIPE DIA. (IN FT.) + 1"

CUT-OUT SIZES

- 1 5" PIPE - 2 2" CUT-OUT
- 1 8" PIPE - 2 7" CUT-OUT
- 2 4" PIPE - 3 6" CUT-OUT
- 3 0" PIPE - 4 4" CUT-OUT
- 3 6" PIPE - 5 0" CUT-OUT

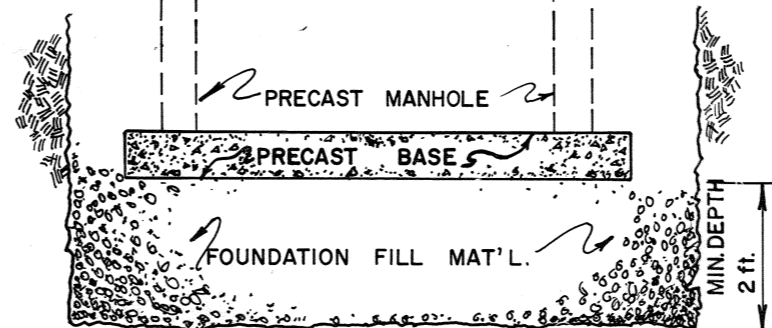
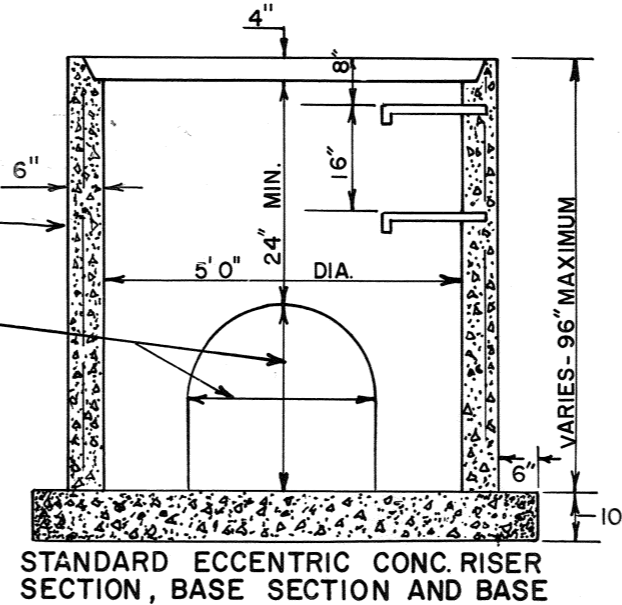

REVISIONS

NO.	DATE	BY	REMARKS
1	5-30-85	L.R.H.	REMOVED DIV. OF PUBLIC WORKS (T. BLK.)
2	7-24-87	D.H.G.	ADD: #5 BAR ; # 4
3	2-3-88	D.H.G.	REMOVED DEPARTMENT (T. BLK.)
4	2-14-11	L.R.H.	REVISED M.H. OPENING

CONVERSIONS

ENGLISH	METRIC

GENERAL NOTES

THIS MANHOLE WILL CONFORM TO THE STANDARD DRAWING UNLESS OTHERWISE SHOWN OR DIRECTED BY THE ENGINEER TO MEET SPECIAL CONDITIONS. THERE WILL NO VARIATION FROM THE CONTRACT PRICE DUE TO SUCH CHANGES. IN ALL CASES IT MUST BE BUILT LARGE ENOUGH TO ACCOMMODATE INLET AND OUTLET PIPES.

THE PRECAST CONCRETE MANHOLE SHALL MEET THE REQUIREMENT AND SPECIFICATION SET OUT IN A S T M - C 478, LAST REVISION

ALL CONCRETE FOR MASONRY TO BE CLASS 'A'

CITY OF MEMPHIS
DIVISION OF ENGINEERING

DESIGN STANDARD
FOR
PRECAST MANHOLE

Ray Mason 10-29-79
PRINCIPAL CIVIL ENGINEER
J.P. Jamery Jr. 10-29-79
DEPUTY DIRECTOR/CIVIL ENGINEER DATE