

BUREAU, STREET DESIGN BUREAU ENGINEER, J.T.C. DATE 6/1/78 SCALE NONE

REVISIONS			
NO.	DATE	BY	REMARKS
1	MAY 21, 1979	J.T.C.	Dimension changes
2	5-30-85	L.R.H.	REMOVED DIV. OF PUBLIC WORKS (T. BLK.)
3	7-22-87	D.H.G.	ADD: 2" CLEAR; CLASS 'A'
4	2-29-88	D.H.G.	REMOVED DEPARTMENT (T. BLK.)

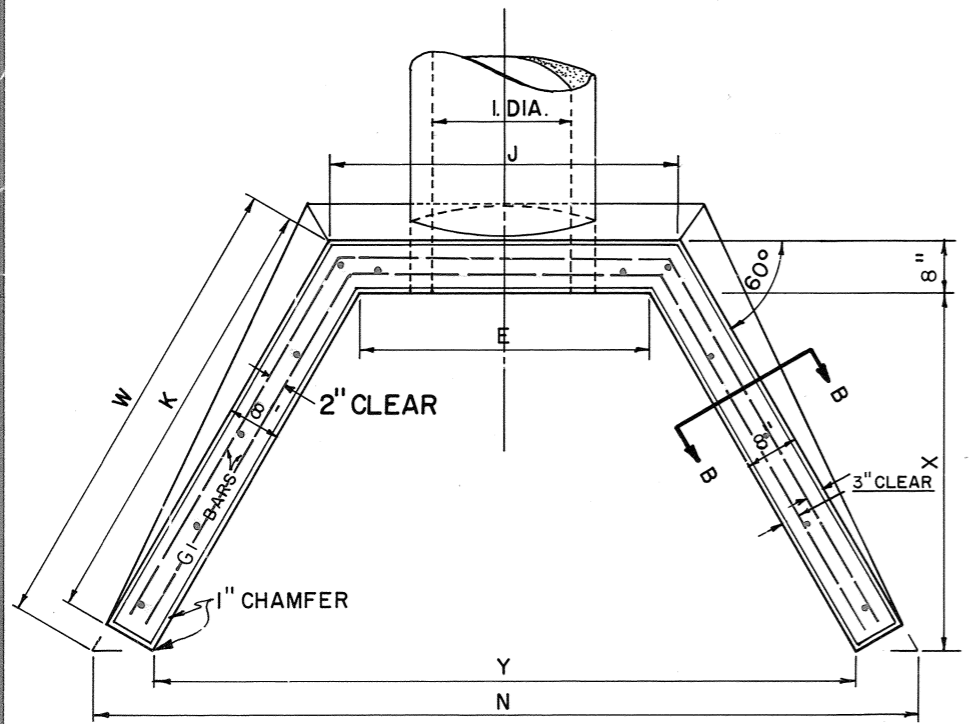

PLAN
INLET

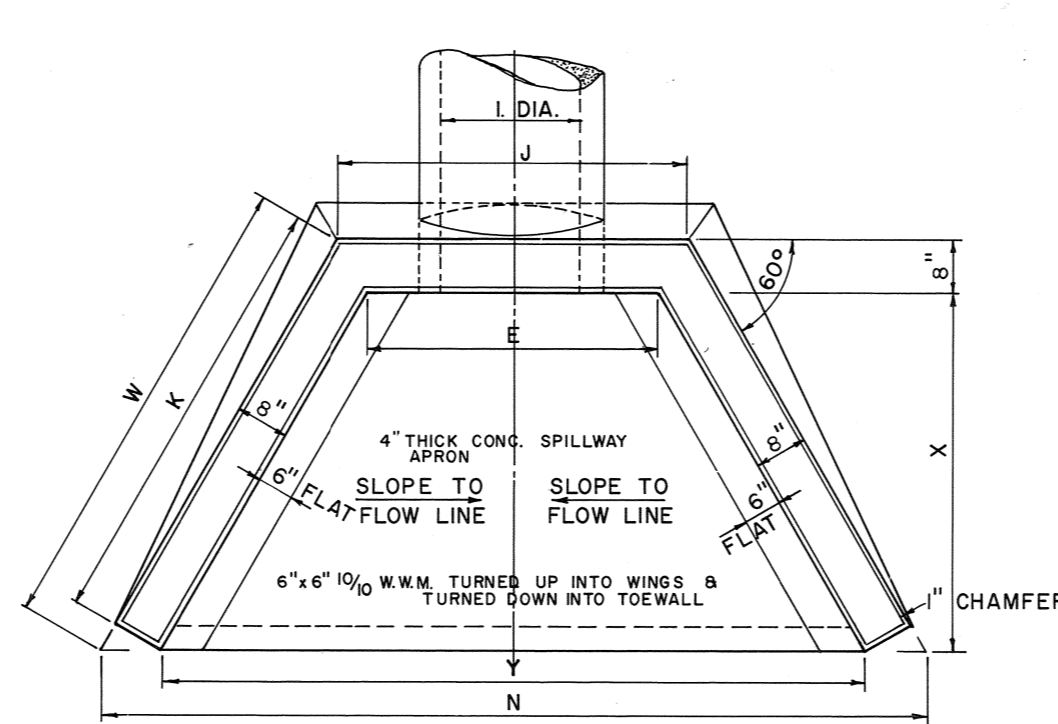

PLAN
OUTLET

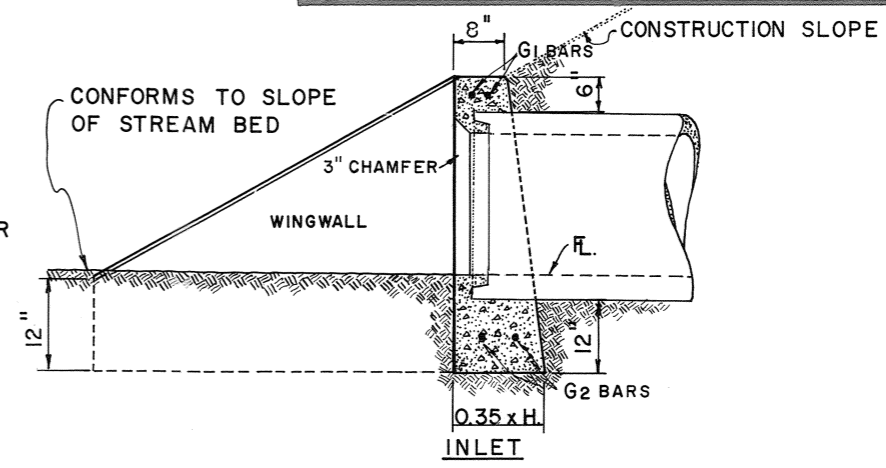

SECTION A-A
OUTLET

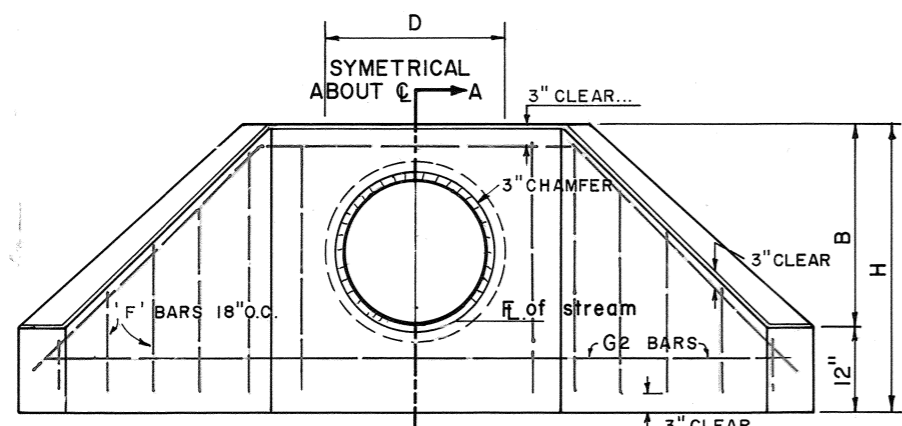

ELEVATION
INLET

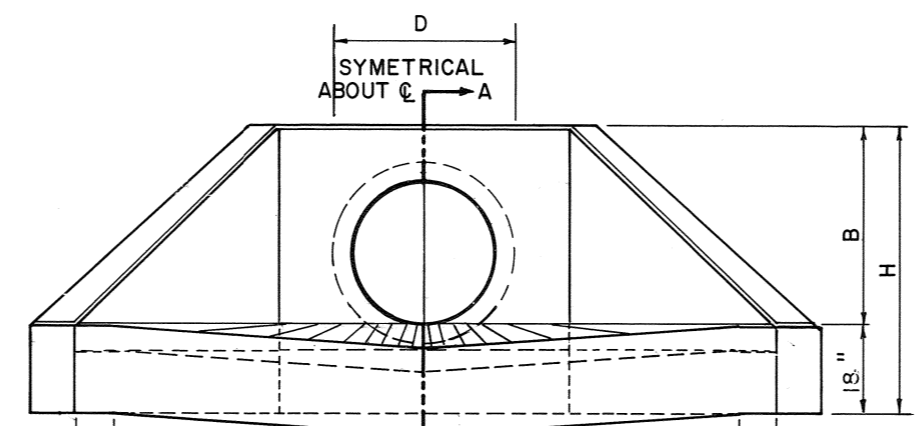

ELEVATION
OUTLET

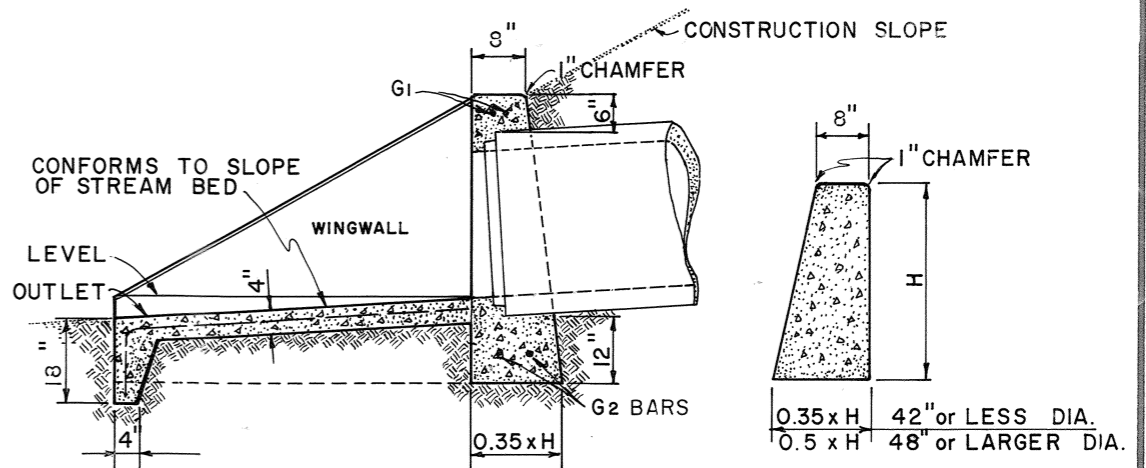

SECTION B-B
WINGWALL SECTION

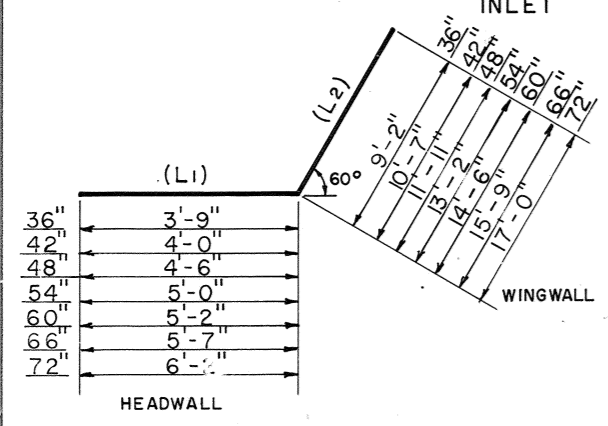

TABLE OF DIMENSIONS AND DIAMETERS*												
DIA.	15"	18"	21"	24"	30"	36"	42"	48"	54"	60"	66"	72"
B	1'-11 1/2"	2'-2 1/4"	2'-5 1/4"	2'-8 1/2"	3'-3"	3'-9 1/2"	4'-4"	4'-10 1/2"	5'-5"	6'-0"	6'-6 1/2"	7'-1"
D	1'-7 1/4"	1'-10 1/2"	2'-1 1/2"	2'-5"	3'-0"	3'-7"	4'-2"	4'-9"	5'-4"	6'-0"	6'-7"	7'-2"
E	1'-9 1/4"	2'-0 1/2"	2'-3 1/2"	2'-7"	3'-2"	3'-9"	4'-4"	4'-10"	5'-6"	6'-2"	6'-9"	7'-4"
H	3'-1 1/4"	3'-4 1/2"	3'-7 1/2"	3'-11"	4'-6"	5'-1"	5'-8"	6'-3"	6'-10"	7'-6"	8'-1"	8'-8"
J	2'-7 5/8"	2'-10 7/8"	3'-17 8/8"	3'-5 3/8"	4'-0 3/8"	4'-10 5/8"	5'-2 3/8"	5'-9 3/8"	6'-4 3/8"	7'-0 3/8"	7'-7 3/8"	8'-2 3/8"
K	4'-10 5/8"	5'-5 3/4"	6'-0 5/8"	6'-8 1/4"	7'-11 1/4"	9'-2 1/4"	10'-5 1/4"	11'-8 1/4"	12'-11 1/4"	14'-3 1/2"	15'-6 1/2"	16'-9 1/2"
N	7'-11 1/2"	8'-9 7/8"	9'-7 7/8"	10'-6 7/8"	12'-4 7/8"	14'-2 7/8"	16'-0 7/8"	17'-10 7/8"	19'-8 7/8"	21'-9 1/8"	23'-7 1/8"	25'-5 1/8"
W	5'-3 3/4"	5'-11"	6'-5 7/8"	7'-1 1/2"	8'-4 1/2"	9'-7 1/2"	10'-10 1/2"	12'-11 1/2"	13'-4 1/2"	14'-8 5/8"	15'-11 5/8"	17'-2 5/8"
X	3'-10 1/4"	4'-4 1/2"	4'-10 1/2"	5'-5"	6'-6"	7'-7"	8'-8"	9'-9"	10'-10"	12'-0"	13'-1"	14'-2"
Y	6'-2 5/8"	7'-1 1/8"	7'-11"	8'-10 1/8"	10'-8 1/8"	12'-6 1/8"	14'-4 1/8"	16'-2 1/8"	18'-0 1/8"	20'-0 1/4"	21'-10 1/4"	23'-8 1/4"

* This Table of Dimensions is for 2:1 Construction Slope

G1 & G2 BARS
#4 RE. BARS

NOTE: RIGHT WING LOOKING INTO PIPE, LEFT WING OPPOSITE HAND
Conc. to be **CLASS 'A'**

CITY OF MEMPHIS
DIVISION OF ENGINEERING

DESIGN STANDARD
FOR
TYPE "D" HEADWALL
with **WINGWALLS**

J. B. Jamu Jr.
DEPUTY CITY ENGINEER

6-12-78
DATE

Foy C. Read
DWG. NO. 28