

REVISIONS			
NO.	DATE	BY	REMARKS
Δ	4/13/21		ADDED NOTE 2

**NOT ACCEPTABLE**

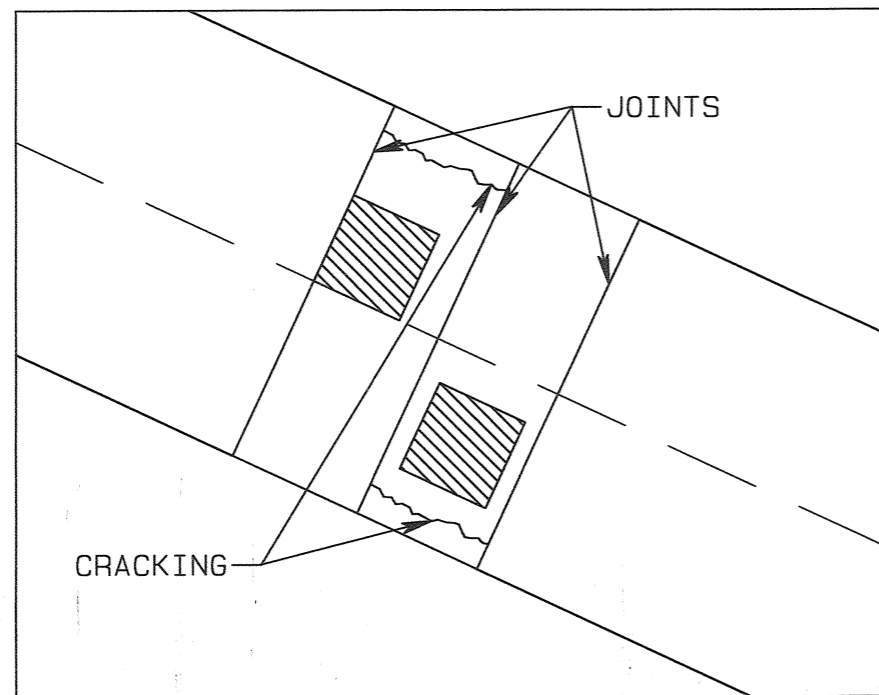

**ACCEPTABLE**

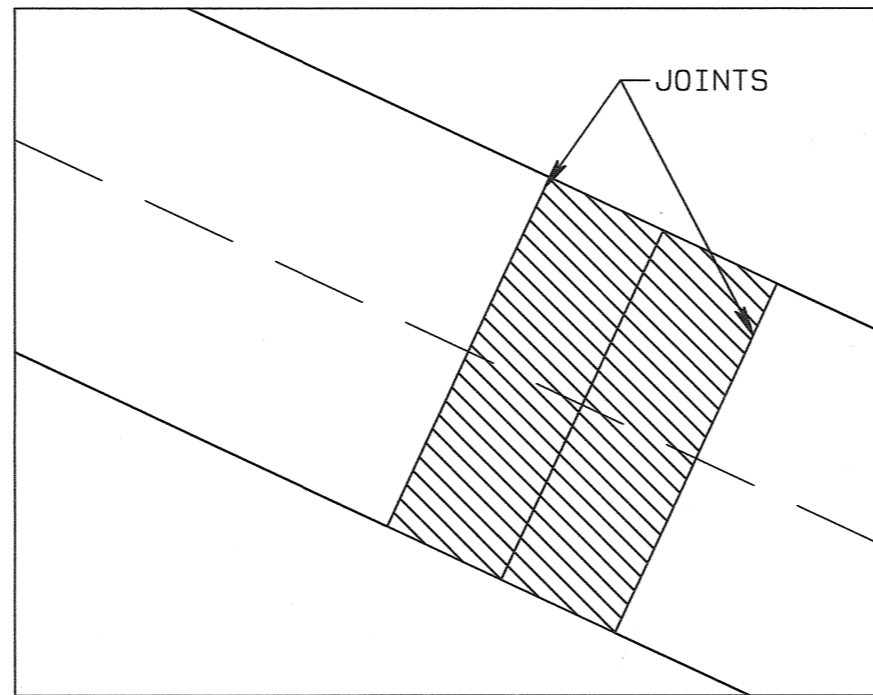

**NOTES**

1. IN CONCRETE PAVEMENTS, REMOVE SECTIONS TO EXISTING JOINTS, OR NEW SAW CUT JOINTS AT MID-SLAB, THAT ARE IN GOOD REPAIR. IN DAMAGED CONCRETE, THE LIMITS OF REMOVAL SHOULD BE DETERMINED IN THE FIELD BY CITY INSPECTIONS.

Δ 2. ALL CUT ASPHALT EDGES TO BE TREATED WITH A TACK COAT

**CITY OF MEMPHIS  
DIVISION OF ENGINEERING**

**DESIGN STANDARD  
FOR  
CONCRETE PAVEMENT REPAIR**

<i>Chae Chew</i> CIVIL DESIGN ENGINEER	12.11.19 DATE
<i>WS</i> CITY ENGINEER	12/11/19 DATE

NOT TO SCALE